

Drill Bits / Ankr Drives / Fasteners / Nails

ANKR DRIVE SYSTEM

This method will fasten metal or tackless to any masonry floor, at a lower cost than drilling and plugging or using contact cement. System consists of two parts:

- (1) **Carbide bit:** drills the right size hole for the Ankr Drive aluminum fasteners.
- (2) **Ankr Drive aluminum fasteners:** have square sides which grip the inside of the round hole securely.

This foolproof system is easy, inexpensive and a practical method of solving installation problems on all masonry surfaces. Proven by more than 20 years of use by carpet installers. There is no better or faster system. 25 lb. cartons; sold by the pound.

No.	Hole Size	Length
AD-58	1/8"	5/8" For all metal trim on masonry floors.
AD-78	1/8"	7/8" For wood tackless or heavier metal trims over composition covered floors.
AD-78-3	3/16"	7/8" Heavy Duty.

SOLID CARBIDE MASONRY BITS & ADAPTERS

Solid carbide bits are specially designed for drilling into any masonry floor with a rotary or hammer drill. Heat treated for wear resistance. These drill the right size hole for the Ankr Drive fasteners shown above. Bits can be resharpened and should last indefinitely if properly used. Adapter is needed to hold the bits in drill chuck to avoid breaking the bits.

Prod No.	Drill Bit	Size	Adapter	Uses This Ankr Drive
GU-8-DB	No. 8	1/8"	No.18	No. 58 & No. 78
GU-10-GB	No.10	3/16"	No.18-3	No. 78-3

CARBIDE TIPPED DRILL BITS

High quality, high speed carbide tipped bits used for drilling into concrete, terrazzo, masonry, etc. Use with the Ankr Drive system. Carried in two sizes; packaged individually.

Prod No.	Size
GA-W1873	3/16"
GA-W1253	1/8"

ANCHOR CONCRETE NAILS

Our Anchor brand tempered nails are made of the highest quality specially chosen steel. Uniform heads, shanks, and points mean less waste on the job. No flying nail heads. The 11/16" nail has smaller head and thinner shank - just right for nailing tackless strip to concrete. Sold by the pound.

Number	Size	Gauge	Approx.nails per lb.	Pack.
AN-12-CN	1/2"	.148"	400	50 lb
AN-58-CN	5/8"	.148"	347	50 lb
AN-34-CN	3/4"	.148"	302	50 lb
AN-1-CN	1"	.148"	214	50 lb
AN-1116-CN	11/16"	.105"	450	50 lb

OVAL HEAD DRIVE SCREWS

For installing metal binder bar. These 1-1/4" long drive screws drive like a nail, hold like a screw. Oval head fits the countersink in metal binder bar. Available in gold & silver; please specify finish desired. Packed loose in 50 lb. cartons; sold by the pound.

Prod No.	Type
No. 695-1	Brass Plated Drive Screws (gold)
No. 695-2	Nickel Plated Drive Screws (silver)

GU-CLT-18 NO. 18 CARPET LAYERS TACKS

Small head tack with uniform sharp point. The most popular tack in the trade. 7/8" long, blued and sterilized. Packed in 1 lb. boxes. 25 lbs. per carton.

GU-O91 ANKORITE PINS

Specially designed pins with extra sharp steel points for use with Ankorite Tool. 1 lb. packages. 20 lbs. per carton.

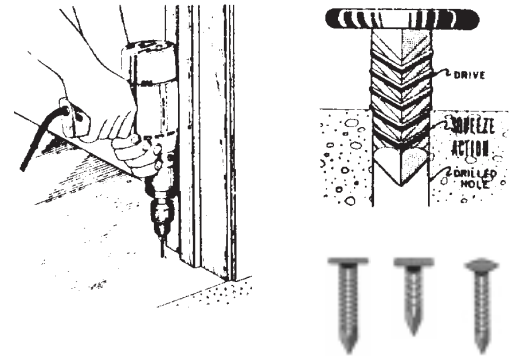

ANKR DRIVE SYSTEM

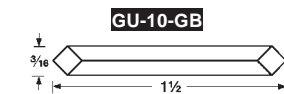
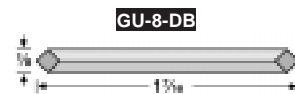

SOLID CARBIDE BITS



Carbide tipped drill bit

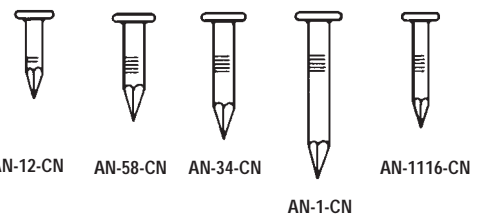

AN-12-CN AN-58-CN AN-34-CN AN-1-CN AN-1116-CN

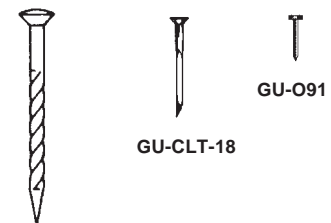

OVAL HEAD DRIVE SCREW

MASONRY FASTENERS / DRILL BITS

NAILS

Call Toll Free

Baltimore 800-556-7899 • Harrisburg 800-421-7575 • Richmond 800-441-2144 • Roanoke 800-575-5655
Raleigh 800-551-0666 • Charlotte 800-896-6710 • Charleston 800-814-1169

Staplers

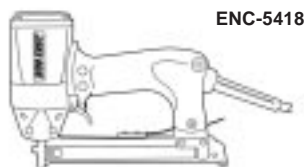

ENC-5418

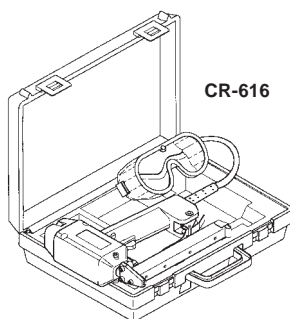

CR-616



SK-9040

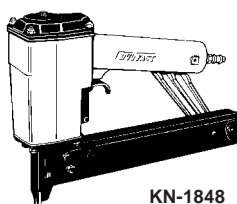

KN-1848

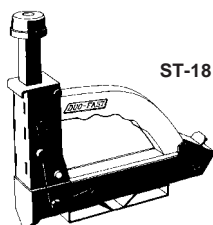

ST-18



AMC-39

Electric Staplers

Electric staplers drive fine wire, narrow crown staples that hide themselves in the carpet pile, and are perfect for upholstering stairs and in any other place where tacks or nails could be used. Drive staples as fast as you can flick the trigger. All of our electric staplers use the same staples: 5412 (3/8"), 5416 (1/2"), or 5418 (9/16"). For hardwood floors use our high carbon steel, rosin coated staples (5412CXR, 5416CXR, or 5418CXR).

ENC-5418 DUO-FAST ELECTRIC STAPLER

A heavy duty professional grade electric tacker, the ENC-5418 is the industry standard. Just plug in and go to work anywhere. Compact and perfectly balanced. Comes complete with carrying case, safety goggles and user's guide. Uses staples listed above. Weighs 4 lb. 2 oz.

CR-616 CRAIN ELECTRIC PRO STAPLER KIT

The Improved Pro Stapler features a powerful 11 amp. solenoid that drives staples into hardwoods. Lower head fits under step risers for easy stapling. Pointed tip helps bury staples into carpet pile. Has safety trigger lock. Magazine holds 100 staples; uses Duo-Fast 5418 staples. Kit includes: No. CR-615 electric stapler, safety glasses and carrying case. Case will hold a box of staples. Complete kit weighs 7 lbs.

Underlayment Staplers

Our underlayment staplers are specially designed for nailing down underlayment board. Choose either the pneumatic (air-driven) or the mallet driven model.

SK-9040 SUPCO PNEUMATIC STAPLER

Powerful yet lightweight! Better balance, lighter weight, and cushioned handgrip make the SK-9040 easier to handle. Uses compressed air to drive narrow-crown 18-gauge staples up to 1-1/2" in length and is ideal for underlayment or tackless strip. Comes with oiler. Uses 1828 (7/8"); 1832 (1"); and 1836 (1-1/8") staples. Open magazine design makes remaining staples visible.

KN-1848 DUO-FAST PNEUMATIC STAPLER

The original genuine Duo Fast brand tool similar to Supco SK-9040. (Special Order)

ST-18 DUO-FAST STRIKE TACKER

A mallet powered tool for installing underlayment. Mallet operated plunger is designed for long, hard use. Stabilizer base holds tool upright for sliding over floor. Uses same narrow crown staples as KN-1848 and SK-9040 pneumatic staplers.

Air Compressor

AMC39 3/4 HP AIR COMPRESSOR [S/O]

A lightweight yet powerful compressor. Use with our pneumatic stapler or any compressed air actuated tool. Features include:

- Comes complete with 50 ft. hose and fittings
- Compact, unique design prevents tip-over
- Start-Stop pressure switch and on/off switch are standard
- Low-amperage draw...runs on 115 volt household current
- 3/4 HP; 125 PSI, overload protected motor
- Rated at 3.9 CFM; delivers 2.6 CFM at 100 PSI
- Cast iron cylinder ensures longer life
- Size: 24"L x 18"W x 12"H; weighs only 51 lbs.

Eye and Face Protection

Eye and face protective equipment is required by OSHA where there is a reasonable probability of preventing injury when such equipment is used. Employers must provide a type of protector suitable for work to be performed, and employees must use the protectors. These stipulations also apply to supervisors and management personnel, and should apply to visitors while they are in hazardous areas.

Staplers

Hammer Tackers

RA-11 RAPID PROLINE STAPLE HAMMER

Tired of sending your staple hammer in for repair? ... Try the Rapid 11! This sturdy tool has only four moving parts; it can be taken apart in seconds and repaired quickly on the job. Comfortable vinyl hand grip; easy back end loading. We carry all replacement parts in stock for the RA-11 staple hammer. Weighs only 2 lb., 3 oz. Uses 10-210 3/8" staples. A simple, lightweight, but durable answer to your carpet padding stapler problems.

RA-100 HACKTACK MULTI STAPLER

Specially designed for perimeter installation of interflex and other perimeter floors. HackTack drives a 3/8" staple under toekicks. Expend less effort, less time on perimeter installations, and eliminate call backs. Staples are driven 3/8" from the wall, so 1/2" quarter round or shoe moulding will hide them. Holds 235 staples; no stopping to reload. Drives staple flush with one blow of the mallet. Mallet is included with tool.

HT-755 DUO-FAST HAMMER TACKER

A popular heavy duty hammer stapler. Drives medium gauge staples as fast as you can swing the tool. Uses 7512D (3/8") or 7516C (1/2") staples.

HT-550 DUO-FAST HAMMER TACKER - Light Duty

A light duty version of the HT-755 hammer tacker. Drives lighter gauge staples. Uses 5010D (5/16") or 5012D (3/8") staples.

RT-10-113 ROBERTS EDGE BINDING STAPLER

Designed to attach binding to rugs. Adjustable depth guide allows quick adjustment for different carpets. Chrome plated steel. Uses No. AN-37-041 (3/8") staples.

GU-G7B-RB Replacement blade for G7B (Special Order only)

R-3 STAPLE REMOVER

Has a comfortable plastic handle and features a hinged blade for varying penetration angles. Has powerful leverage for easy work, and is 8" long overall. Weighs 5 oz.

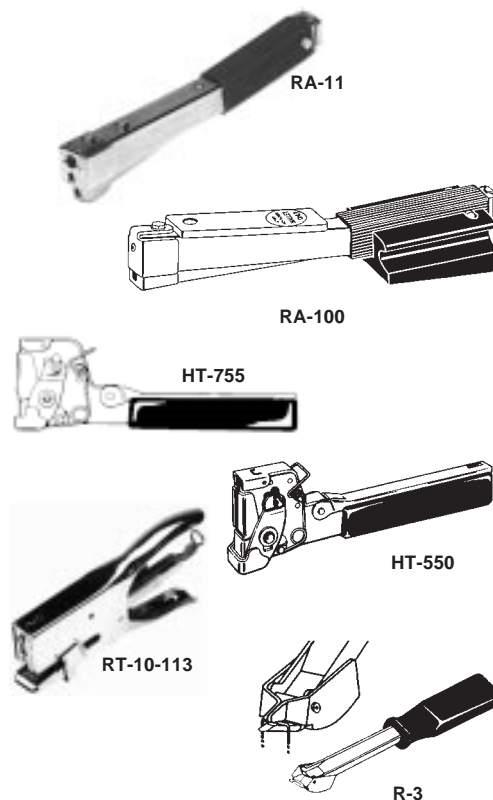

STAPLERS

UNDERLAYMENT

Tecply Premium Underlayment Board

TECPLY UNDERLAYMENT BOARD

There is no better underlayment board made for sheet vinyl!!! Tecply is made of 5 plies of extremely hard solid arctic white birch, so it resists indentation better than any other underlayment board. The unique 5 ply construction is stronger and more stable than 3 ply board, and it resists warping and bending better. Exterior phenolic adhesive withstands boiling, so Tecply won't delaminate even when wet. Dimensionally stable; free of harmful formaldehyde emissions; and has no core voids. Exact thickness from sheet to sheet means less time sanding and patching (Manufactured to tolerance of 0.2 mm). 4' x 4' sheets are easier to handle with less damage to the corners and edges. 100 sheets per pallet. Guaranteed for life of the floor or 10 years not to delaminate and not to cause staining on vinyl sheet goods. Toll free tech support line (888-283-2759) is available to all Tecply users.



Underlayment Board Tips

1. Porous boards such as luan, poplar and particle board will absorb adhesives very readily leaving little to hold the flooring. To prevent this problem, first "skin coat" the underlayment board with a very thin coat of the adhesive using a flat blade trowel. Then spread the adhesive using the proper notch trowel for the particular floor covering. The extra adhesive used will more than be compensated for by a correct and superior bond of your installation.
2. Certain underlayment boards are not recommended by the sheet vinyl flooring manufacturers. Consult them before you use any particular board. Warranties may be voided if you use a non-approved board. Tec Ply™ is accepted by many major sheet vinyl manufacturers.
3. All underlayment manufacturers specify certain nailing patterns as well as how joints are to be treated. For a flawless underlayment installation insure that all pertinent installation instructions are followed. We carry a complete line of fastening devices and approved patching materials. We also stock belt sanders for boards requiring sanding only at the joints.
4. During the past 30 or more years we have inspected many, many jobs — large and small — where there was a claim that the adhesive was not holding. We found that **almost never** was the adhesive at fault. We have also received many complaints of the underlayment joints "showing" through the sheet vinyl. We found in every case that the underlayment boards manufacturers' installation instructions had not been followed.

Call Toll Free

Baltimore 800-556-7899 • Harrisburg 800-421-7575 • Richmond 800-441-2144 • Roanoke 800-575-5655
Raleigh 800-551-0666 • Charlotte 800-896-6710 • Charleston 800-814-1169

Staples

STAPLES

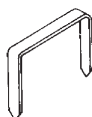

Chisel Point Staple

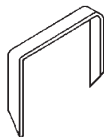

Divergent Point Staple

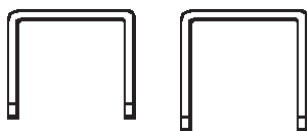

5/16" 3/8"

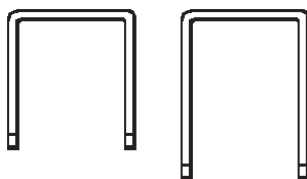

7/16" 9/16"

Note: The letters following the staple numbers describe the points and finishes as follows:

- C** Chisel Point
- D** Divergent Point
- X** High Carbon Steel (extra hard)
- G** Galvanized – rust resistant
- (*)** Special Order Only

Our **Anchor brand** staples are made for us in the U.S. from the highest quality high carbon steel wire. Our large purchasing power allows us to save you money on these staples. Unconditionally guaranteed. If not completely satisfied, return for full credit.

For Use in Staper No.	Length	Staple Pack	Bxs per ctn.	Manufacturer's Brand	Anchor Brand
				Staple No.	Staple No.
DUO-FAST:					
SK-9040 or KN-1848 or ST 18	7/8"	4,400	8	DF-1828C	
		14,400	1	DF-1828-11	
		5,000	10	—	AN-1828C
	1"	13,200	1	DF-1832-11^(*)	—
		5,000	10	—	AN-1832C
	1-1/8"	13,200	1	DF-1836-11^(*)	—
5,000		10	—	AN-1836C	
ENC 5418 or ROBERTS 10-112 or CRAIN 616	9/16"	5,000	20	DF-5418C	—
	9/16"	5,000	20	—	AN-5418D
HT 755	3/8"	5,000	20	DF-7512D	AN-7512D
	1/2"	5,000	20	DF-7516C	—
HT 750	5/16"	5,000	20	DF-7510D	AN-7510D
HT 550	5/16"	5,000	20	DF-5010D	AN-5010D
CT 859	3/8"	5,000	20	DF-5010D	AN-5010D
LTN 834A	3/8"	5,000	50	DF-3412C	—
SPOTNAILER:					
3807	7/8"	5,000	10		AN-777CX
BOSTITCH:					
P6 RB	3/8"	5,000	20	—	AN-STH-2619
H2B	3/8"	5,000	20	—	AN-SHCR-5019
ROBERTS:					
10-109 or RAPID-11	3/8"	5,000	20	—	AN-10-210D
	3/8"	5,000	20	—	AN-10-110C
10-113	5/16"	5,000	20	—	AN-37-041

Explanation of staple points: **Chisel** point staples drive straight and allow for easier later removal. **Divergent** point staples twist when driven to give best holding power.

Nailing Concrete Tackless

Nailing concrete strip can be made easier if you insert a scrap piece of vinyl flooring between the strip and the concrete ... this cushions the nail giving it something to bite into before entering the concrete.