

Universal Moulding System

The ideal way to finish all types of carpet, tile, wood and ceramic flooring. The Universal Moulding System consists of two parts: an aluminum (or rigid plastic) base track, and a flexible vinyl insert that is snapped into the track. This system offers a flexible choice of solutions to join flooring materials of different heights or thicknesses. It also makes smoother inside or outside curves than metal or vinyl trims. Seven different shapes of inserts will solve almost every problem.

Base Track

Prod No.	Product	Pcs/Ctn	Pack
Pinless – Metal & Plastic – For glue down			
MD-4	Plastic Base Track	20	240 ft
752	Metal Base Track – Pinless	20	240 ft
752C	Contour Metal – Pinless*	12	144 ft
Pin Type – Metal – For Tackless Installation			
751	Base Metal - Pin Type	20	240 ft
751C	Contour Base Metal - Pin Type	12	144 ft

Vinyl Inserts

Prod No.	Product	Use
CD-xx-C	Standard T (3/4" face)	For two materials of same height.
CD-xx	Super T (1-1/2" face)	For two materials of same height.
CD-xx-A	Super T - High leg	Carpet to carpet.
CE-xx-A	Carpet to Tile Adapter	Join 5/16" cpt to 1/8" resilient.
CD-xx-B	Carpet to Vinyl Adapter	Join 1/2" to lower height vinyl.
CE-xx-B	Mini Carpet to Tile	For materials of different heights.
CE-xx-C	Carpet to Ceramic	For carpet to ceramic tile.

To order inserts replace "xx" with two digit color number.

Vinyl Inserts Color Chart

06 – Diablo Red *	33 – Adobe Peach*	58 – Windsor Blue *
07 – Woodviolet	34 – Almond	59 – Heather Green *
15 – Cabernet *	40 – Black *	60 – Taupe *
16 – Teal	42 – Sable *	63 – Burnt Umber *
18 – Navy Blue *	45 – Sandalwood *	76 – Cinnamon
19 – Desert Camel *	47 – Brown *	80 – Fawn *
20 – Charcoal *	48 – Grey *	85 – Burgundy *
22 – Pearl *	49 – Beige *	86 – Hunter Green *
28 – Med. Grey *	53 – Mauve	92 – Blue Lagoon *
29 – Moon Rock *	55 – Silver Grey *	

Universal moulding inserts are available in all of the colors shown on the color chart above. We stock all of the insert shapes in Black; most of them in colors 28-Med. Gray, and 76-Cinnamon; some in 49 Beige. All others are available from the mill. Asterisks (*) indicate Color Match® colors.

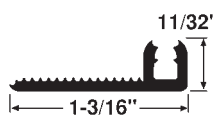
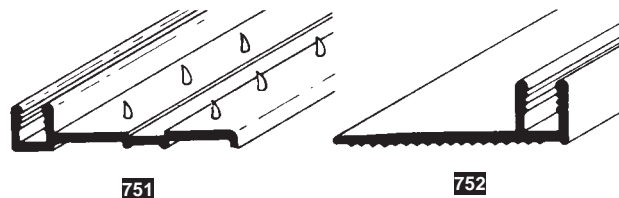

MD-4

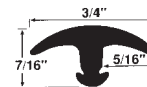

CD-xx-C

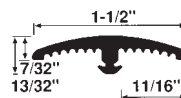

CD-xx

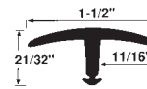

CD-xx-A

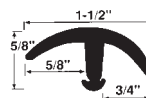

CD-xx-B

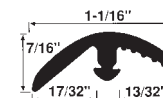

CE-xx-A

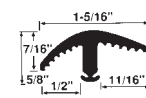

CE-xx-C

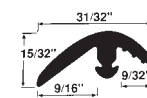

CE-xx-B

Installing Vinyl in Universal Base Track

When installing vinyl into universal base track, cut the vinyl to length and fit it at both ends first.

Then work from both ends to the middle, and force any apparent excess into the track.

If you work from one end to the other, or from the middle to the ends, the vinyl will stretch. When the vinyl shrinks back to its original length (and it will!) you'll have to replace it because the insert will be too short.

For Installations Requiring A Length Less Than 12 Feet:

1. Measure the opening to the nearest 1/16 of an inch. Cut the T-cap profile 3/8 to 1/2 of an inch longer than the opening measurement, and align the vinyl in position over the retaining track.
2. Butt one end of the T-cap firmly against the wall and insert approximately one foot of the vinyl into the track using a rubber mallet. When inserting the vinyl, slightly angle the mallet head back towards the starting point.
3. Next, move to the opposite end of the vinyl. Butt this end firmly against the wall and install as above.
4. Complete the installation by alternating between each side of the opening and installing 1 to 2 feet of T-cap at a time.

Call Toll Free

Baltimore 800-556-7899 • Harrisburg 800-421-7575 • Richmond 800-441-2144 • Roanoke 800-575-5655
Raleigh 800-551-0666 • Charlotte 800-896-6710 • Charleston 800-814-1169

Vinyl Trims - Carpet / Resilient / Walls

All of the Johnsonite shapes and trims shown in this section are made in the 24 Colormatch™ colors; see page F-18 for the Colormatch™ color chart. We stock most shapes in colors: 40-Black; 76-Cinnamon; 49-Beige; and 28-Medium Gray. Special order items normally take only 5-8 working days.

VINYL TRIM

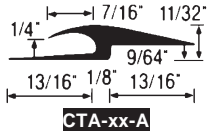

CTA-xx-A

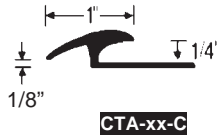

CTA-xx-C

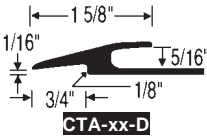

CTA-xx-D

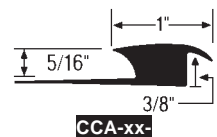

CCA-xx

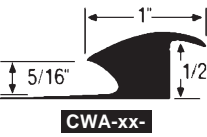

CWA-xx

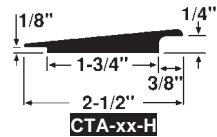

CTA-xx-H

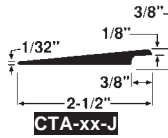

CTA-xx-J

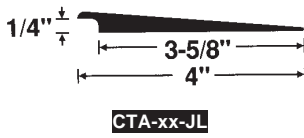

CTA-xx-JL

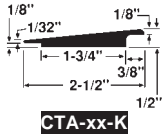

CTA-xx-K

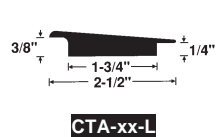

CTA-xx-L

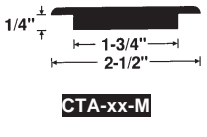

CTA-xx-M

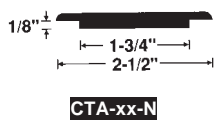

CTA-xx-N

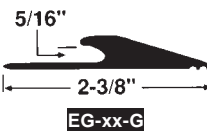

EG-xx-G

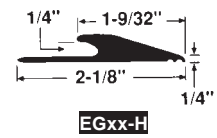

EGxx-H

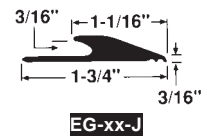

EG-xx-J



EG-xx-K

Adaptors / Transitions

CTA-xx-A CARPET TO TILE ADAPTER

A one piece "T" moulding for transition between carpet and tile. 1/4" carpet to 1/8" resilient. Face is 1 3/8" wide. 12 ft. sections; 20 pieces (240 ft) per carton.

CTA-xx-C CARPET TO TILE ADAPTER - JR.

Smaller version of CTA-xx-A.; Face is only 1". 12 ft. sections; 20 pieces (240 ft) per ctn.

CTA-xx-D COMMERCIAL CARPET TO TILE ADAPTER

For 5/16" carpet to 1/16"-1/8" resilient. Heavy center post for commercial installations to stand up under the weight of heavy rolling carts. 12 ft. sections; 20 pieces (240 ft) per ctn.

CCA-xx CARPET TO CERAMIC ADAPTER

One piece "T" moulding for transition between 5/16" carpet and 3/8" ceramic flooring. 12 ft. sections; 10 pieces (120 ft) per carton.

CWA-xx CARPET TO WOOD ADAPTER

One piece "T" moulding for joining 5/16" carpet to 1/2" wood flooring. 12 ft. sections; 10 pieces (120 ft) per carton.

Wheeled Traffic Transitions

A group of transition mouldings designed for rolling traffic; specially suited for health care applications. These shapes allow wheeled and ambulatory traffic to glide easily and smoothly between different flooring surfaces with varying heights. Exceeds ADA recommendations for "change of level" transitions. All are made in 12 ft. Sections; 10 pieces (120 ft) per carton.

Number	Transition	Face
CTA-xx-H	1/4" to 1/8"	2 1/2"
CTA-xx-J	1/4" to 0"	2 1/2"
CTA-xx-JL	1/4" to 0"	4"
CTA-xx-K	3/8" to 1/8"	2 1/2"
CTA-xx-L	3/8" to 1/4"	2 1/2"
CTA-xx-M	1/4" to 1/4" Level	2 1/2"
CTA-xx-N	1/8" to 1/8" Level	2 1/2"

Edge Guards

EDGE GUARD ("Imperial Reducer")

Edge guard combines undercut, flange, and transition. Guide-notched for butting to resilient materials. EG-xx-K is designed for use with artificial grass carpet or as a cove cap with thin carpet. 12 ft. sections; 20 pieces (240 ft) per carton.

Style No.	Undercut Size
EG-xx-G	5/16"
EG-xx-H	1/4"
EG-xx-J	3/16"
EG-xx-K	3/16"

Mitered Corners In Universal Moulding

1. Cut opposing 45° angles on the end of two lengths of T-cap.
2. Align one of the 45° angled pieces in the corner of the track and insert approximately one foot of the length as previously described.
3. Install the other 45° angled piece in the same manner.
4. Depending on the length of the T-cap section, use Section "A" or "B" to install the remaining portion of the vinyl lengths.

Vinyl Trims - Carpet / Resilient / Walls

Reducers

CARPET REDUCER STRIPS

A neat trim for glue-down carpet installations. Available in two sizes.

Style No	Undercut Size	Pack	Ft/Ctn
CRS-xx-A	1/4" x 1-1/2"	20 ft coil; 10 / ctn	200
CRS-xx-C	3/16" x 1"	50 ft coil; 6 / ctn	300
CRS-xx-D	1/2" x 2"	12 ft coil; 10 / ctn	120

CRS-xx-B TERRA TURF REDUCER

Reducer designed specially for Terra-Turf flooring and similar 3/8" tire cord entry tiles and matting. See page F-86 for Terra-Turf. 12 ft. sections; 10 pieces (120 ft) per carton.

CRS-xx-E TRANSITION REDUCER

A wide, gradual transition reducer for glue down carpet where there is heavy rolling traffic, such as hospitals, hotels, or department stores. Has 2-1/2" bevel face and 9/32" butting gauge. 12 ft. sections; 10 pieces (120 ft) per carton.

RESILIENT REDUCER STRIPS — (TILE REDUCERS)

The perfect finish for edges of resilient floors. Comes in three butting gauges: 1/16", .080", and 1/8"; all 1-1/4" wide. 3 ft. sections; 50 pieces (150 ft) per carton.

Style No.	Butting Gauge
RRS-xx-A	1/16"
RRS-xx-B	.080"
RRS-xx-C	1/8"

When ordering, replace the "xx" in the Style No. Column with the two digit color number.

Johnsonite Leveler System

NEW!! The Johnsonite Leveler System allows abruptly uneven subfloors to be quickly and easily transitioned to each other without patching or leveling compounds. Check these features and benefits:

- Saves time and money: easy to install by novice or professional installer.
- Eliminates need to feather edge with patching compound.
- Automatically provides smooth, gradual transition to adjacent subfloor.
- Install new flooring immediately—no waiting for leveling compound to dry and cure.
- May eliminate need for reducers, adapters or thresholds.
- Will not crack or crumble over time.

Johnsonite Leveler System						
No.	Transition		Width	Length / Piece	Pieces / Carton	Feet / Carton
	From	To				
LS-40E*	1/2"; Or 3/8"; Or 1/4"	3/8"; 1/4"; or 0" 1/4"; or 0" 0"	12"	4 ft	5	20
LS-40D*	3/8"; Or 1/4"; Or 1/8"	1/4"; 1/8"; or 0" 1/8"; or 0" 0"	12"	4 ft	5	20
LS-40	1/4"	0"	12"	4 ft	10	40
LS-40 F	1/8"	0"	12"	4 ft	20	80
LS-40C	1/2"	3/8"	6"	4 ft	6	24
LS-40B	3/8"	1/4"	6"	4 ft	8	32

* Note: LS-40D and LS-40 E Leveler Strips can be cut at premarked scoring lines to create shorter transitions to 1/8", 1/4" or 3/8" gauge materials when needed.

EJS- xx EXPANSION JOINT SEAL

NEW!! A heavy duty "T" for inserting into expansion joints in floor to allow movement of tile below the cap. Keeps tile from cracking. 1-1/2" cap covers joint and keeps dirt out. 12 ft. Sections; 10 pieces (120 ft) per carton.

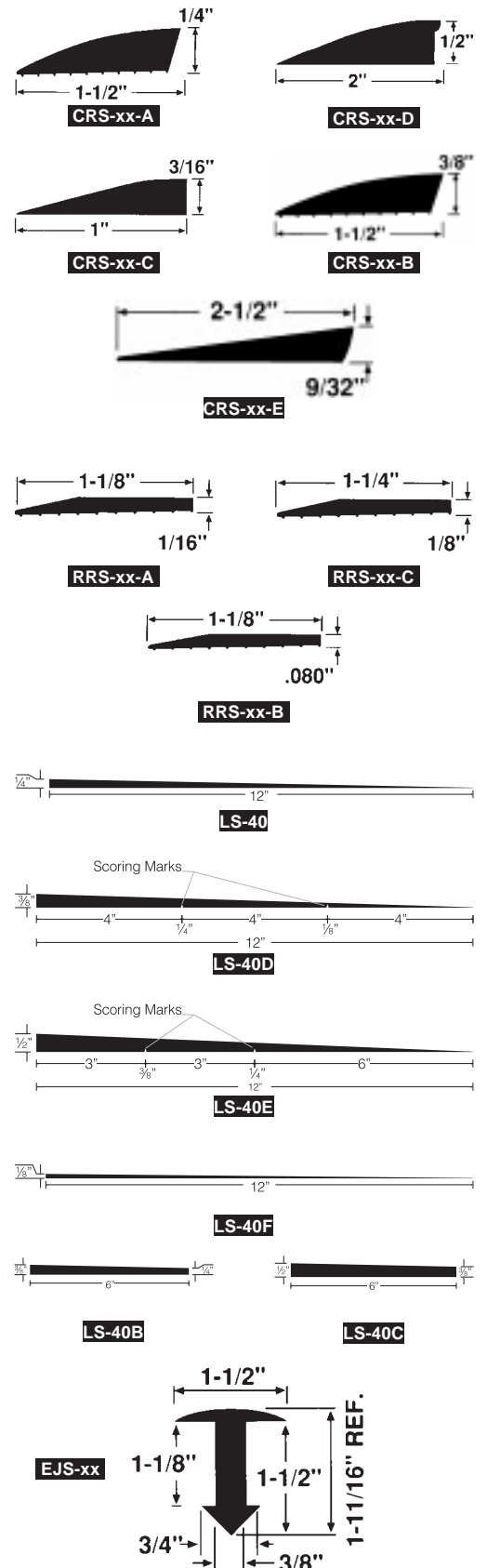

VINYL TRIM

Call Toll Free

Baltimore 800-556-7899 • Harrisburg 800-421-7575 • Richmond 800-441-2144 • Roanoke 800-575-5655
Raleigh 800-551-0666 • Charlotte 800-896-6710 • Charleston 800-814-1169

Vinyl Trims - Carpet / Resilient / Walls

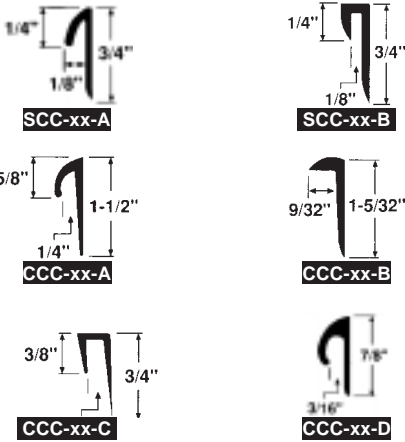

Caps

Use No. SCC-xx-B for covered sheet vinyl; use No. CCC-xx-C for covered carpet, wood paneling or ceramic tile.

Style number	Cap Shape	Opening Size	Length	Pcs / Ctn	Ft / Ctn
SCC-xx-A	Round	1/8"	12 ft.	50	600 ft.
SCC-xx-B	Square	1/8"	12 ft.	50	600 ft.
CCC-xx-A	Round	1/4"	12 ft.	20	240 ft.
CCC-xx-B	"L"	9/32"	12 ft.	50	600 ft.
CCC-xx-C	Square	1/4"	12 ft.	40	480 ft.
CCC-xx-D	Round	3/16"	12 ft.	20	240 ft.

When ordering, replace the "xx" in the Style No. column with the two digit color number.

Vinyl Stair Nosing - Carpet

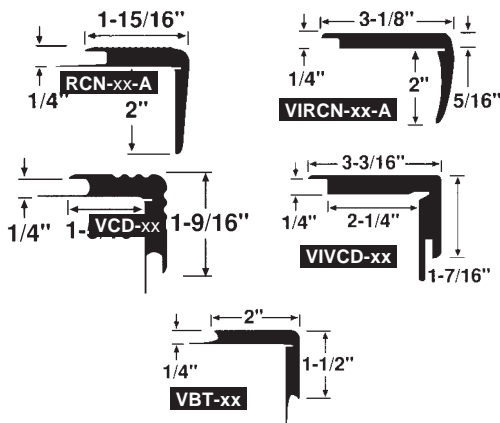

RCN-xx-A CARPET STAIR NOSING

VIRCN-xx-A CARPET STAIR NOSING - VISUALLY IMPAIRED

A heavy duty and versatile nosing. Undercut for 1/4" or 5/16" carpet. Heavily grooved nosing for safety. Long 1-3/4" nose and extended flange insure firm adhesion to stair. 12 ft. sections; 10 pieces (120 ft) per carton. VIRCN has 2" contrasting visually impaired strip, and is packed 6 pieces (72 ft) per carton.

VCD-xx DOUBLE UNDERCUT CARPET STAIR NOSING

VIVCD-xx DOUBLE UNDERCUT CARPET STAIR NOSING - VISUALLY IMPAIRED

Unique double undercut design permits protection of tread and riser carpet edges. Undercuts will handle 1/4" or 5/16" carpets. Non-slip tread surface is a safety feature. 12 ft. sections; 10 pieces (120 ft) per carton. VIVCD has 2" contrasting visually impaired strip and hinged nose and is packed 5 pcs (60 ft) per ctn.

VBT-xx DOUBLE BUTT CARPET STAIR NOSING

For use on square nosed step. Double butt edge for 1/4" carpets. Smooth tread surface. 12 ft. sections; 10 pieces (120 ft) per carton.

Vinyl Stair Nosing - Resilient

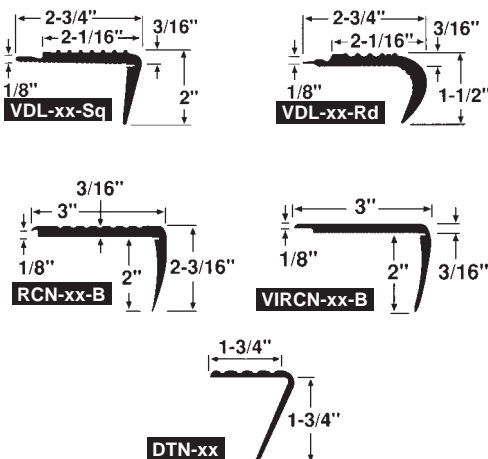

VDL-xx-Sq. SQUARE VINYL STEP NOSING* (Hinged)

A vinyl stair nosing with square nose. 1/8" butting gauge for sheet vinyl, tile and low profile carpet. Flange can be cut off for 3/16" goods. Non-slip top measures 2-1/16". 12 ft. sections; 10 pieces (120 ft) per ctn.

VDL-xx-Rd. ROUND VINYL STEP NOSING* (Hinged)

Same as VDL-xx-Sq, but with a round nose. 12 ft. sections; 10 pieces (120 ft) per ctn.

RCN-xx-B OVERLAP STAIR NOSING* (Hinged)

VIRCN-xx-B OVERLAP STAIR NOSING - VISUALLY IMPAIRED* (Hinged)

Overlap Stair Nosing features extra large 3" tread area, extra-long 1-7/8" nose, and curved overlap lip. Lip covers 1/16" to 1/8" tile or sheet goods. Lip may be cut for 3/16" butting gauge. 12 ft. sections; 10 pieces (120 ft) per carton. VIRCN has 2" contrasting visually impaired strip.

DTN-xx RESIDENTIAL STAIR NOSING

Applied-after residential stair nosing. 12 ft. sections; 10 pieces (120 ft) per carton.

* Hinged for superior fit.

Vinyl Corner Guards - (Bumper Guards)

Vinyl Corner Guards are the perfect protection for corners in commercial installations. Johnsonite corner guards are made from unique designs, are flexible, will not crack or chip like rigid plastics, and won't shrink. Easy to install and maintain. Three different shapes are available; each shape in two lengths. Choose from the table below in any of the 24 Color-match® colors or the additional colors listed. *Special order only.*

Style No.	Return Size	Length	Pcs / Ctn	Ft / Ctn
VBG-xx-48	2 3/8"	4 ft.	8	32 ft.
VBG-xx-96	2 3/8"	8 ft.	8	64 ft.
VBG-xx-A-48	1 1/2"	4 ft.	8	32 ft.
VBG-xx-A-96	1 1/2"	8 ft.	8	64 ft.
VBG-xx-B-48	3/4"	4 ft.	8	32 ft.
VBG-xx-B-96	3/4"	8 ft.	8	64 ft.

When ordering, replace the "xx" in the Style No. column with the two digit color number.

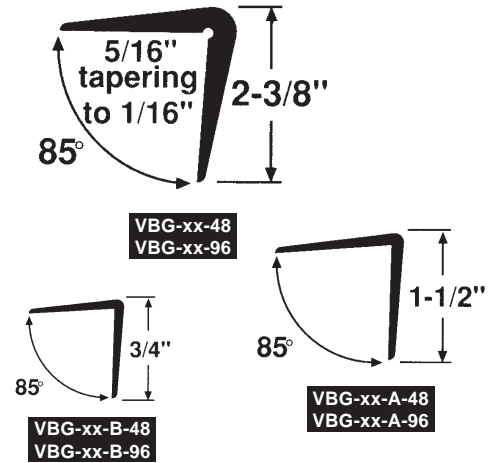

VINYL TRIM

Vinyl Trims - Specialty Shapes

TUB & TILE MOULDINGS

Mirror finish cove for bathtubs, counters, shelves, etc. Has self sticking adhesive. 5 ft. sections; 24 pieces (120 ft) per carton. Made in white only. Two sizes are available.

Style No.	Butting Height
TM-50	1 1/2"
TM-50-A	1"

Order exactly as shown.
Do not specify any color number.

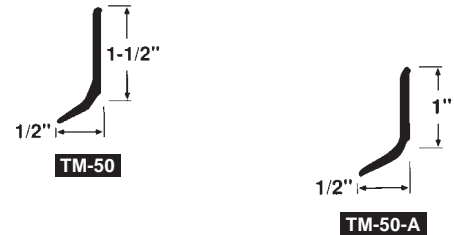

SSR-xx-B OVERLAP RESILIENT REDUCER

Overlap reducer is the perfect alternative to metal binder bar for use on resilient floor materials. 35 ft. coils; 2 coils (70 ft) per carton.

COVE STICK

A plastic cove stick for coving sheet goods. Has zero-taper edges. Made in neutral only; no colors are available.

Style No.	Radius	Length	Pcs / Ctn	Ft / Ctn
CFS-00	1 - 3/4"	12 ft.	12	144 ft.
CFS-00-A	7/8"	12 ft.	32	384 ft.

Order exactly as shown. Do not specify any color number.

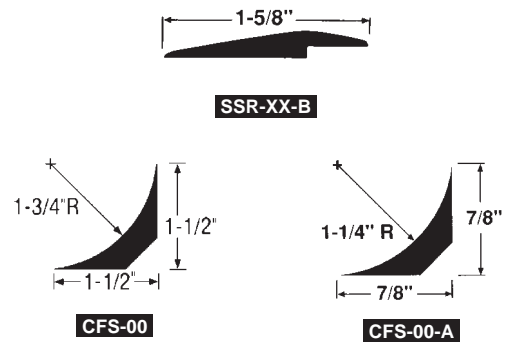

Surface Preparation For Wall Base

Floors and walls must be clean, dry, free of dust, oil, all paints, wall paper etc. Wall surface must reach down to within 1/4" of the floor and be structurally sound. Do not install wall base over vinyl wall coverings or other nonporous surfaces. First remove the vinyl wall covering to within 1/4" below the top edge of the wall base so the adhesive can contact the wall. Neutralize soft alkaline plaster with a coating of zinc sulfate mixed one pound per gallon of water. Never install wall base on walls that will be exposed to drastic temperature changes or moisture. Consider using TightLock® Wall Base if walls are in poor shape or do not reach down to within 1/4" of the floor. See page F-16.

Call Toll Free

Baltimore 800-556-7899 • Harrisburg 800-421-7575 • Richmond 800-441-2144 • Roanoke 800-575-5655
Raleigh 800-551-0666 • Charlotte 800-896-6710 • Charleston 800-814-1169

Metal Mouldings

Our own Ankr Trim™ metal mouldings give you an unequalled choice of style, color and quality in a variety of weights. All metals come in 12 ft. lengths unless specified otherwise.

Ankr Trim™ metals are carried in 3 basic finishes:

Hammered Aluminum... standard silver color.

Hammered Gold... an outstanding and unusual bright gold color that is a Fishman exclusive produced by a unique manufacturing process. Far more attractive than the standard dull satin finish of other makes of metal.

Hammered Satin Brass... a satin brass color, softer than our bright gold.

Hammered Coventry Gold... a rich, dark shade, less expensive than our bright gold.

Hammered wear surface hides scratches and scuff marks.

Binder Bars

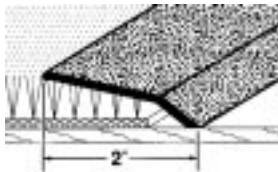

605

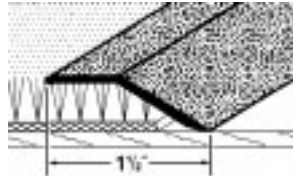

305

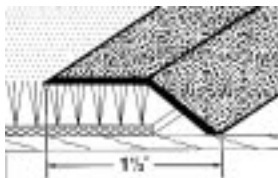

A348

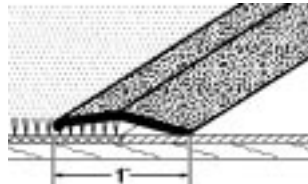
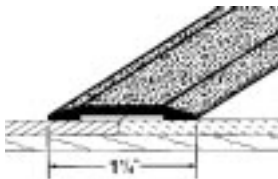
304
302

A366

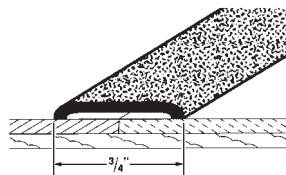

A366X

Number	Width	Finish	Pack	Pcs/Ctn
605 2" HEAVY WEIGHT CARPET METAL				
605H	2"	Hammered Alum.	144 ft.	12
605HG	2"	Hammered Gold	144 ft.	12
605HSB	2"	Hamm. Satin Brass	144 ft.	12
305 1 1/2" CARPET METAL - Premium Weight				
305H	1-1/2"	Hammered Alum.	480 ft.	40
305HG	1-1/2"	Hammered Gold	480 ft.	40
305HSB	1-1/2"	Hamm. Satin Brass	480 ft.	40
305CVG	1-1/2"	Hamm. Coventry Gold	480 ft.	40
A348 1 1/2" CARPET METAL - Standard Weight				
A348H	1-1/2"	Hammered Alum.	480 ft.	40
A348HSB	1-1/2"	Hamm. Satin Brass	480 ft.	40
304 1" TILE METAL - Heavy Weight				
304H	1"	Hammered Alum.	144 ft.	12
304HG	1"	Hammered Gold	144 ft.	12
304HSB	1"	Hamm. Satin Brass	144 ft.	12
304CVG	1"	Hamm. Coventry Gold	144 ft.	12
302 1" TILE METAL - Economy Grade				
302H	1"	Hammered Alum.	144 ft.	40
302HSB	1"	Hamm. Satin Brass	144 ft.	40
<i>No. 302 is not stocked at all locations.</i>				
A366 1 1/4" LINO BINDER BAR				
A366H	1 1/4"	Hammered Aluminum	144 ft.	12
A366HSB	1 1/4"	Hamm. Satin Brass	144 ft.	12
A366X 3/4" LINO BINDER BAR				
A366XH	3/4"	Hammered Aluminum	144 ft.	12
A366XHSB	3/4"	Hamm. Satin Brass	144 ft.	12

Metal Installation Tip

Make perfect mitered corners easily using our GU-201 Airway Miter Box. See page F-67 for details.

See page 98 for ordering information from our 12 branches.

Visit our Website at www.fishman.com

Clamp Down Metals

METAL TRIM

458 HEAVY DUTY COMMERCIAL CLAMP DOWN METAL

For commercial installations. Extra heavy lip will stand up under heavy traffic in department stores, airports, etc. 1-3/8" lip; 2-1/8" bottom flange.

Number	Finish	Pack	Pcs/Ctn.
458H	Hammered Aluminum	144 ft.	12
458HG	Hammered Gold	144 ft.	12
458HSB	Hamm. Satin Brass	144 ft.	12

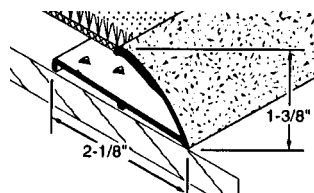

458

454 PREMIUM QUALITY CLAMP DOWN METAL

Our most popular and best looking clamp down metal. Used at doorways and in areas where carpet butts to hard surface flooring. Excellent for heavy and medium traffic areas and for the finished look on the true tackless method. 3/4" lip; 1-7/16" bottom flange.

454H	Hammered Aluminum	480 ft.	40
454HG	Hammered Gold	480 ft.	40
454HSB	Hamm. Satin Brass	480 ft.	40

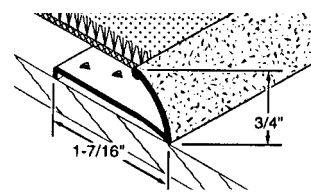

454

456 SUPER PREMIUM QUALITY CLAMP DOWN METAL

A heavier version of our 454 metal. Extra thickness means extra wear. Outstanding quality for heavy and medium traffic areas. 3/4" lip; 1-5/8" bottom flange.

456H	Hammered Aluminum	480 ft.	40
456HSB	Hamm. Satin Brass	480 ft.	40

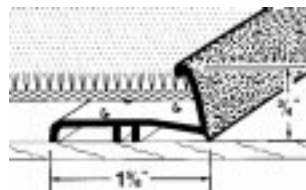

456

457 "CONTOUR" CLAMP DOWN METAL ("Flex" metal)

Clamp down metal pre-notched for making free form curves. Metal may be curved in either direction. If curved and straight sections are to be used on the same job, use our No. 454 for the straight sections.

457H	Hammered Aluminum	144 ft.	12
457HG	Hammered Gold	144 ft.	12
457HSB	Hamm. Satin Brass	144 ft.	12

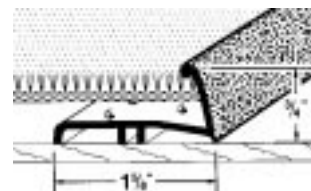

457

452 ECONOMY CLAMP-DOWN METAL

A light weight, but serviceable, clamp down metal for light traffic areas where price is the prime consideration. 9/16" lip; 1-1/2" bottom flange.

452H	Hammered Aluminum	480 ft.	40
452HSB	Hamm. Satin Brass	480 ft.	40

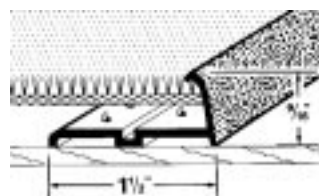

452

650 PINLESS CLAMP-DOWN

Use with any type of glue-down carpet installation. Metal may be nailed or glued to the floor.

650H	Hammered Aluminum	144 ft.	12
650HG	Hammered Gold	144 ft.	12
650HSB	Hamm. Satin Brass	144 ft.	12

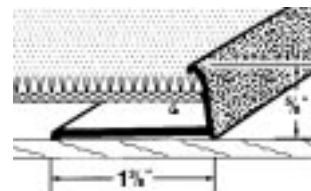

650

599 ECONOMY GRADE PINLESS CLAMP DOWN

A lighter weight version of our pinless clamp down metal. Use in light traffic areas where economy is a prime consideration.

599H	Hammered Aluminum	144 ft.	12
599HSB	Hamm. Satin Brass	144 ft.	12
599CVG	Hamm. Coventry Gold	144 ft.	12

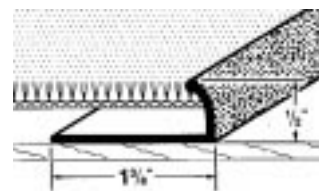

599

599F "FLEX" ECONOMY GRADE PINLESS CLAMP DOWN

A pre-notched version of 599 pinless clamp down metal for making free form curves. Metal may be curved in either direction.

599FH	Hammered Aluminum	144 ft.	12
599FHSB	Hamm. Satin Brass	144 ft.	12

No. 599 and 599F are not stocked at all locations.

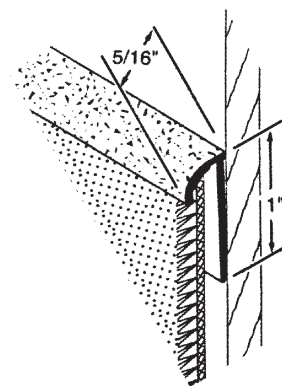

37200

37200 CARPET COVE CAP

Metal trim designed for mounting on wall as a finish for coved carpet.

37200H	Hammered Aluminum	144 ft.	12
37200HG	Hammered Gold	144 ft.	12
37200HSB	Hamm. Satin Brass	144 ft.	12

Call Toll Free

Baltimore 800-556-7899 • Harrisburg 800-421-7575 • Richmond 800-441-2144 • Roanoke 800-575-5655
Raleigh 800-551-0666 • Charlotte 800-896-6710 • Charleston 800-814-1169

Divider Bars

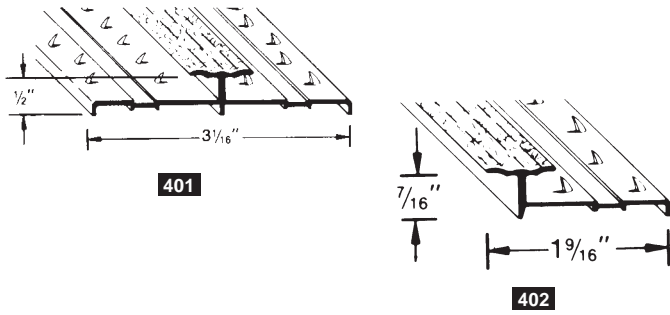

401 TWO-WAY DIVIDER BAR - PIN TYPE

Eliminates costly seaming and reduces maintenance costs. Ideal for use in doorways of hotels, motels or wherever two different carpet colors meet.

Number	Finish	Pack	Pcs/Ctn.
401H	Hammered Aluminum	144 ft.	12
401HG	Hammered Gold	144 ft.	12

402 ONE-WAY DIVIDER BAR - PIN TYPE (S/O)

Similar to No. 401, above, but with only one flange. Use where conventional carpet meets tile, raised terrazzo, sponge-back carpet, etc.

402H	Hammered Aluminum	144 ft.	12
402HG	Hammered Gold	144 ft.	12

Stair Nosing

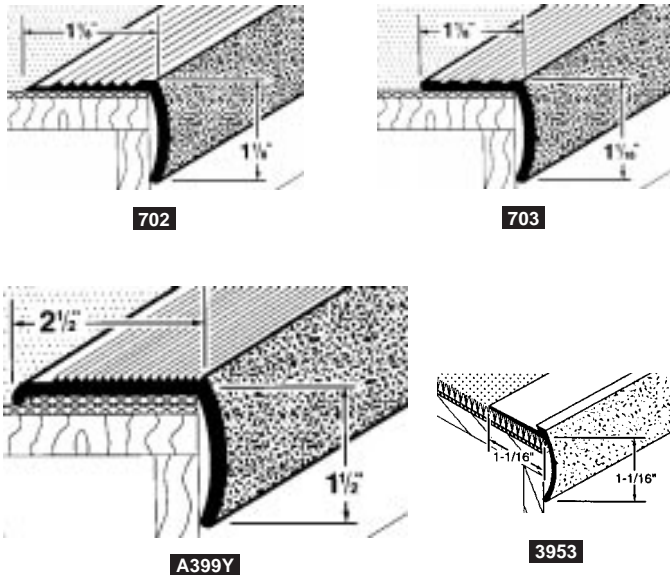

702 TOP SET STAIR NOSING - PREMIUM QUALITY

Our top of the line, top set stair nosing.

Number	Finish	Pack	Pcs/Ctn.
702 H	Hammered Aluminum	144 ft.	12
702 HG	Hammered Gold	144 ft.	12
702 HSB	Hamm. Satin Brass	144 ft.	12
702 CVG	Hamm. Coventry Gold	144 ft.	12

703 TOP SET STAIR NOSING - MEDIUM DUTY

Our medium quality top set stair nosing.

703 H	Hammered Aluminum	144 ft.	12
703 HSB	Hamm. Satin Brass	144 ft.	12

A399Y EXTRA WIDE TOP SET STAIR NOSING

2" wide stair nose. Use where extra wear surface is needed. This nosing is made in polished (not hammered) finish.

A399Y	Polished Aluminum	144 ft.	12
A399Y SB	Smooth Satin Brass	144 ft.	12

3953 "SCRIBE TO" STAIRNOSING

Scribe-to stairnose is designed to be used where no metal is to show on the tread. The tile or sheet goods are scribed to the edge of the nosing.

3953 H	Hammered Aluminum	144 ft.	12
3953 HSB	Hamm. Satin Brass	144 ft.	12

Other Metals

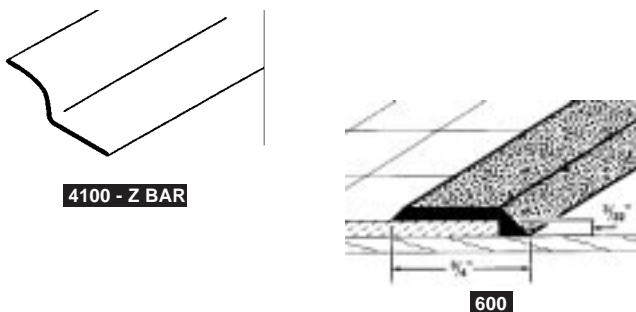

4100 GRIPPER EDGE (2 BAR)

Invisible binder bar for flush hearths, closet doorways and other non-traffic areas. Smooth aluminum, packed 25-4 ft. lengths (100 ft.) to a carton.

600 LINOLEUM EDGE BAR

Shows less metal than 1" binder bar.

Number	Finish	Pack	Pcs/Ctn.
600 H	Hammered Aluminum	144 ft.	12
600 HG	Hammered Gold	144 ft.	12
600 HSB	Hamm. Satin Brass	144 ft.	12

LATE BREAKING NEWS

Also See Page 95

SOLID OAK TRIM

CERAMIC TILE EDGE TRIM

Solid Oak Trims

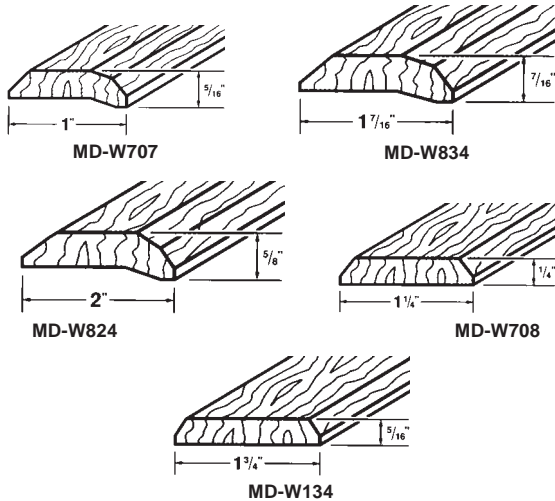

Made from clear grade natural unfinished solid oak. 6 ft lengths are shrink wrapped with screws. Carpet trims transition from soft or hard higher surface to hard lower surface. Seam binders cover seam between level, hard surfaces.

SOLID OAK TRIMS

MD-W707	1" Carpet Trim
MD-W834	1 7/16" Carpet Trim
MD-W824	2" Carpet Trim
MD-W708	1 1/4" Seam Binder
MD-W134	1 3/4" Seam Binder

Ceramic Tile Edge Trim

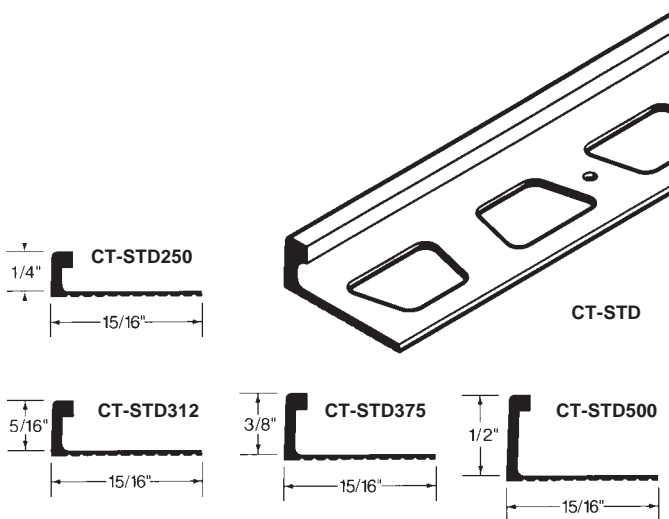

Ceramic Tile Edge Trim is designed to protect the edges of ceramic, marble and natural stone tile. Carried in four heights for all popular tile thicknesses - 1/4"; 5/16"; 3/8"; and 1/2". Three attractive finishes to match every decor: silver; brass; and bright gold. Large perforations in the leg give better bond with thin set mortar. Serrated on bottom surface for better bond with tile adhesives. Nail holes are drilled every 3" for easy fastening to underlayment. 8 foot lengths packed 12 pieces (96 ft.) per tube.

HEIGHT	FINISH		
	SILVER	BRASS	GOLD
1/4"	CT-STD250 SCA	CT-STD250 SBA	CT-STD250 BDB
5/16"	CT-STD312 SCA	CT-STD312 SBA	CT-STD312 BDB
3/8"	CT-STD375 SCA	CT-STD375 SBA	CT-STD375 BDB
1/2"	CT-STD500 SCA	CT-STD500 SBA	CT-STD500 BDB

FISHMAN

See page 98 for ordering information from our 12 branches.

Visit our Website at www.fishman.com